



Silicon Photonics Workshop: Industry Requirements

Andreas Håkansson @
WORLD OF PHOTONICS CONGRESS
2011-05-23, Munich, Germany

www.dasphotonics.com

The Outline:

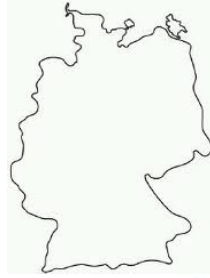

- I. DAS Photonics: *Who we are and what we do*
- II. Packaging & Testing
- III. SiPh Product development at DAS

I. DAS Photonics

LOCATION: DAS Photonics is placed in Valencia, in the eastern part of Spain in the Mediterranean coast.



I. DAS Photonics



DAS Photonics is a spin-off from Nanophotonics Technology Center (NTC). The company develops innovative products based on photonics technology for three markets: Defense, Avionics, Space.



CONFIDENTIAL

www.dasphotonics.com

I. DAS Photonics

Target markets:

- Defence and security
- Avionics
- Space

Technologies:

- Silicon Photonics
- Microwave Photonics
- Digital Photonic Links
- RF Electronics



I. DAS Photonics

- Synergy with NTC
- SiPh based SoC development for our system products



II. Packaging & Testing

- Packaging and Fabrication @ NTC



Wire Bonding



SB²-M

Solder bumping



FC 150

II. Packaging & Testing

- Packaging and Fabrication @ NTC

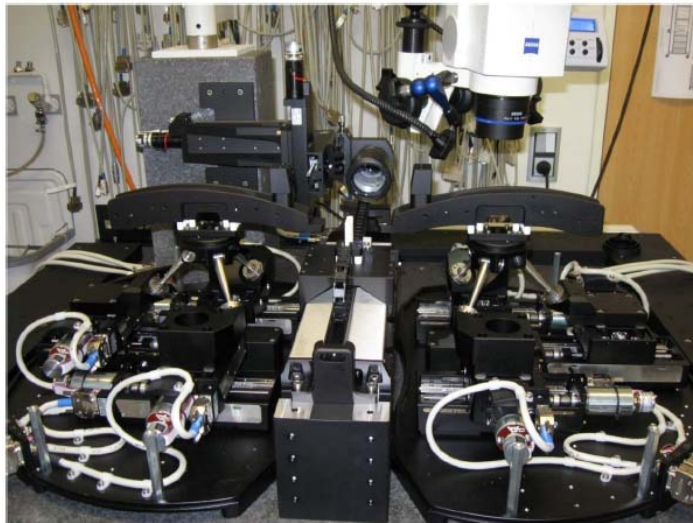

Alignment and Pigtailed Bench

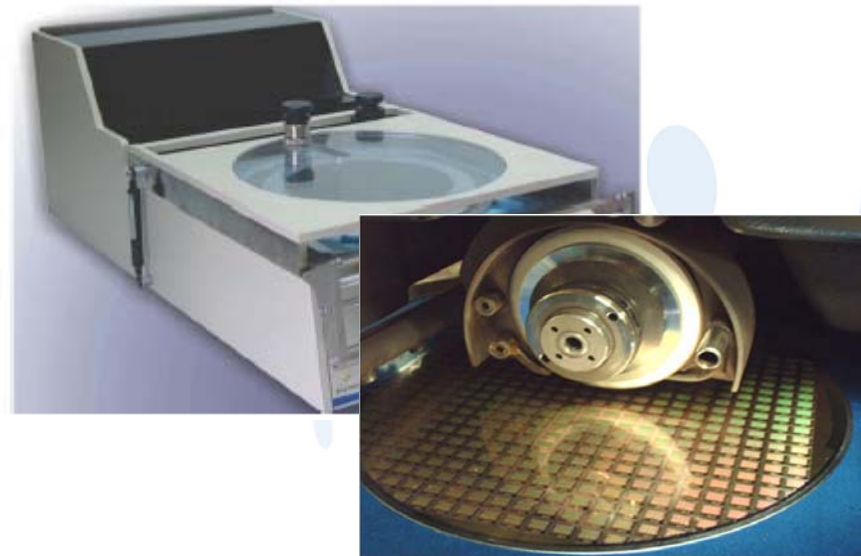

Dicing Line

II. Packaging & Testing

- Testing @ DAS

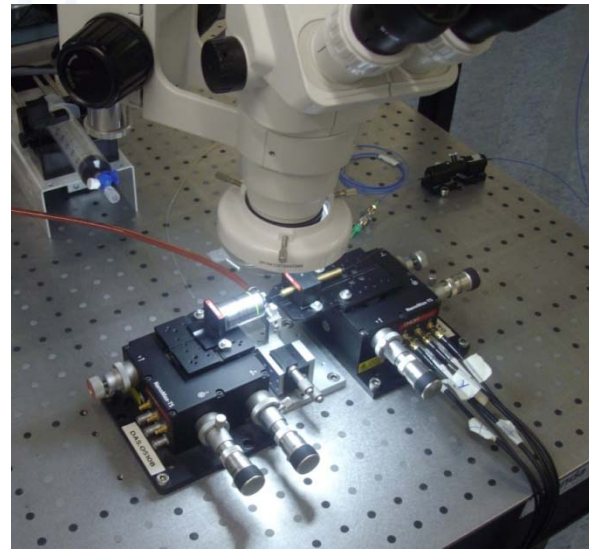
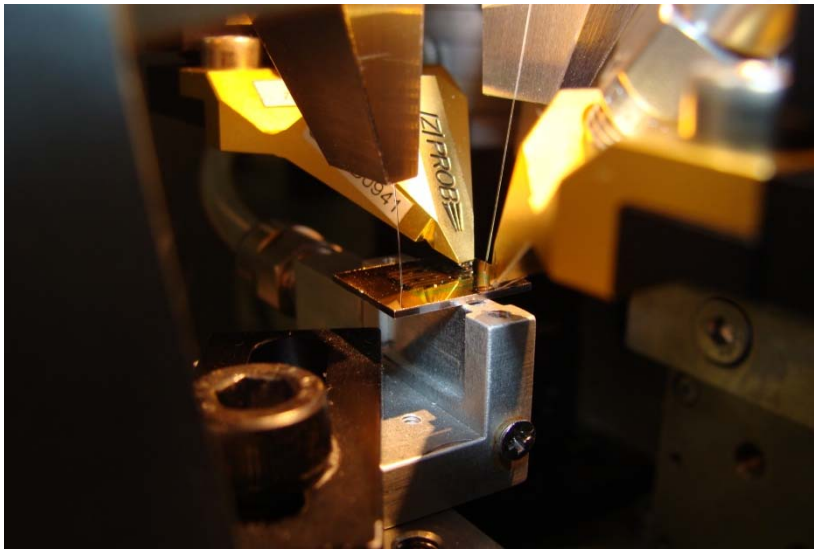

III. SiPh Product development

- **Added Value:** We look for photonic products that will be a unique solution or increase in performance (low cost is not a prime target)
- **SSI or MSI:** Integration of discrete photonic components (between 10-100) on one single chip (VLSI the future)
- **Low volume:** Specific ASPIC solutions for photonic SoC. We do not compete within “high volume markets”.
- **Products:** Beam-forming networks, RF filters, Photonic Sensors, specific wireless/wired communication systems.

III. SiPh Product development

- **Wireless link:** A patented unique solution for 10Gbps wireless DQPSK modulation link at millimeter wave frequencies (60GHz).
- **Beam-forming network:** A photonic matrix with multiple input and multiple output for satellite beam steering applications.
- **Photonic Sensors:** Bio and CBRN sensors for military applications.
- **RF filters:** Typically high Q notch filters.

III. SiPh Product development

Wireless link

- Tx and Rx chip for 10Gbps wireless DQPSK transmission at mm-wave frequencies
- Higher modulation formats
- Elimination costly components such as LO

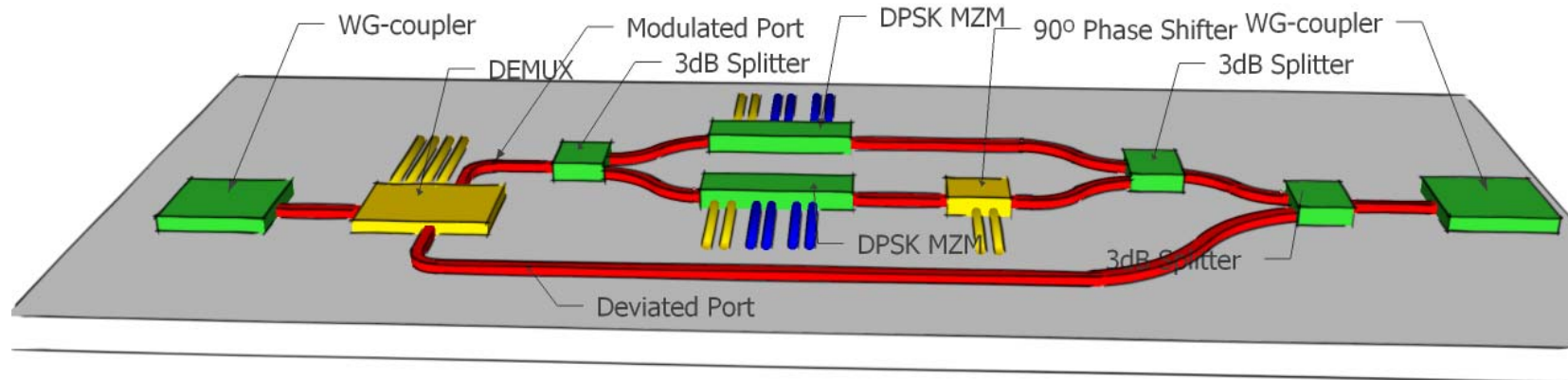

III. SiPh Product development

Wireless link

- Tx and Rx chip for 10Gbps wireless DQPSK transmission
- 12 layers and ~200 designs
 - Delay lines
 - Switches
 - Tunable ring-resonators
 - Add-drop filters
 - MZI modulators
 - RF Photo-detectors

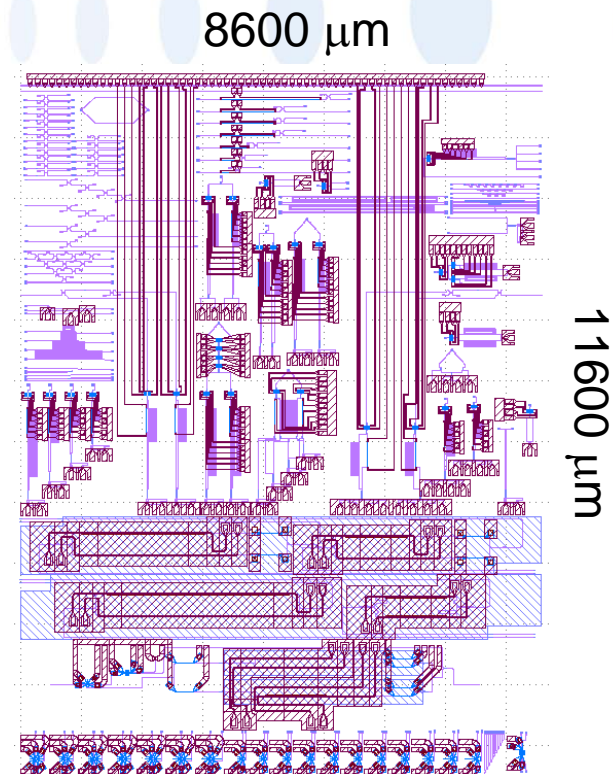

III. SiPh Product development

Optical phase matrix: Beam forming network for satellite applications

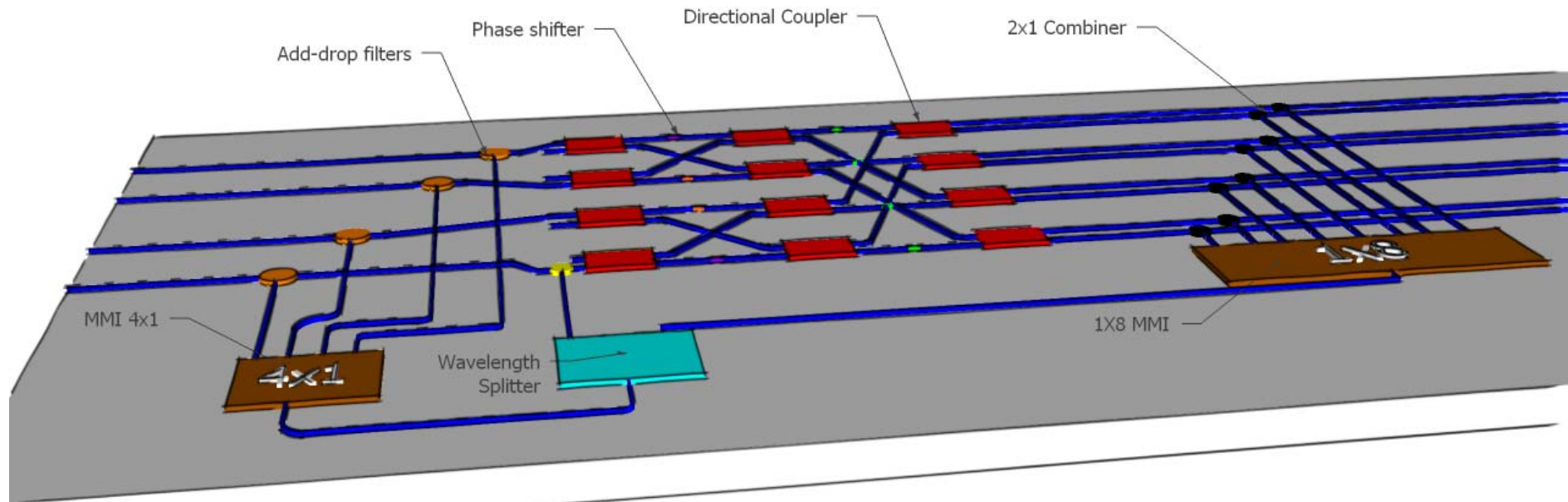

III. SiPh Product development

What are the challenges related to those products?

- **Loss:** Low loss is a must in many of these systems.
- **Integration:** Seamless integration of multiple components on the same chip.
- **Coherence:** Phase coherence
- **Test:** Test of SoC solution.

III. SiPh Product development

Why Silicon Photonics?

- Experience
- Large library of passive and active
- Electronic - Photonic convergence

III. Product development

Testing:

- SoC Includes many components on the same chip. Testing each individual component might be necessary depending on the system. This is a challenge.
- To test each individual component on a chip/module. Solution through specific designs?
- Horizontal or Vertical? Wafer scale testing?

IV. Product development

Packaging:

- Non-standard packages for space and defence applications
- Harsh temperature or other external extreme environment parameters
- Pros/cons of passive alignment, active alignment, in plane coupling, surface coupling, multifiber coupling?



Thank you for your attention!

Questions?